

RIGGERS WINCH 500

Installation Manual – Intended for specialized personnel or expert users

INRW500 11/15



Introduction

| | |
|--------------------------|---|
| Safety Precautions | 3 |
| Applications/Limitations | 4 |
| Specification | 5 |

Installation

| | |
|-------------------|---|
| Plan Installation | 6 |
| Pre-Use Checks | 7 |

Operation

| | |
|----------------|---|
| Lifting Loads | 8 |
| Lowering Loads | 9 |

Maintenance

| | |
|-------------|-------|
| Inspection | 10 |
| Maintenance | 10 |
| Disassembly | 11-13 |
| Cleaning | 14 |
| Assembly | 15-17 |

Declaration of Conformity

18

Parts

| | |
|---------------|-------|
| Exploded View | 19-20 |
| Parts List | 21-22 |

Please read these instructions carefully before installing, servicing, or operating the equipment.
This manual may be modified without notice. In the event of this manual being translated, the English version is definitive. For latest manual revision go to www.harkenindustrial.com/manuals
PLEASE SAVE THESE INSTRUCTIONS

Safety Precautions

Service Manual

You can download the Service Manual from www.harkenindustrial.com/manuals. This manual is for use only by specialized personnel. Installation, disassembling and reassembling by personnel who are not experts may cause serious damage to property or injury to users and those in the vicinity of the product. Harken® accepts no responsibility for damage or harm caused by not observing the safety requirements and instructions in the service manual. See limited warranty, general warnings, and instructions at www.harkenindustrial.com/manuals.

Introduction

This manual gives technical information on installation and service. If you do not understand an instruction, contact Harken®.



DANGER! This indication alerts you to imminent hazards that will kill or seriously injure you and others if you don't follow instructions. The message will tell you how to reduce the chance of injury.



WARNING! This indication alerts you to potential hazards that may kill or seriously injure you and others if you don't follow instructions. The message will tell you how to reduce the chance of injury.



CAUTION! This indication alerts you to potential hazards that may hurt you and others if you do not follow instructions. The message will tell you how to reduce the chance of injury.



WARNING! Strictly follow all instructions to avoid potential hazards that may kill or hurt you and others. See www.harkenindustrial.com/manuals for general warnings and instructions.



This product, as supplied by Harken®, is considered to be applicable to general lifting operations. Should this product be incorporated into systems for lifting persons, it becomes “partly completed machinery” and, when appropriate additional safety devices are added, must be certified for its intended application. Such systems are classified as “machinery for lifting persons” and would require separate CE marking.



Please read these instructions carefully before operating equipment.

Keep these instructions in a safe place for future reference.

CONTENTS SUPPLIED

| Part No. | Description | Quantity |
|-----------|-------------------------------------|----------|
| A96889400 | Harken Radial Winch | 1 |
| F83256700 | B10AL Harken Winch Handle (lock-in) | 1 |
| A96885400 | Plate | 1 |



A. USE

Harken® Riggers Winch 500 is designed to be used as a manually powered, rope-handling winch secured on a universal mounting plate, for lifting, lowering and pulling loads.

B. LIMITATIONS

DO NOT USE:

- With wire rope
- With loads in excess of the maximum working load of 500kg for lifting loads.

C. TRAINING

This equipment must be installed and used by persons trained in its correct application and use.

D. STANDARDS

This product/system has been certified to EN13157 standards.

E. TESTING

Maximum working loads are 4:1 coefficient ratio of the breaking load.



WARNING! As reported in the Directive 2009/104/EC "Persons may be lifted only by means of work equipment and accessories provided for that purpose. Without prejudice to Article 5 of Directive 89/391/EC, exceptionally, work equipment which is not specifically designed for the purpose of lifting persons may be used for that purpose, provided appropriate action has been taken to ensure safety in accordance with national legislation and/or practice providing for appropriate supervision".



WARNING! Subjecting the winch to loads above the maximum working load can cause the winch to fail or pull off the mounting surface suddenly, possibly resulting in severe injury or death.

Specifications

DESCRIPTION

Lightweight CE certified portable winch, mounted on an adaptor plate.

The winch can be utilized in many applications; from utility masts, telecoms, marine, wind-turbine transition piece, davits, stage and theatre rigging.

The adaptor plate can be affixed in a number of ways, dependant on the environment and industry; from ratchet straps, M10 bolts, karabiners, to scaffold clamps. This makes for a truly universal and adaptable lifting solution.

FEATURES

Maximum Grip – The drum’s gripping surface is designed specifically to work with the drum diameter and material to maximize gripping power and reduce rope wear. Diagonal ribs stop the rope from rising (keeping rope wraps on part of drum where you have the best control), prevent overrides, and provide a smooth controlled release as rope exits the winch.

Spring-loaded, self-tailing jaws adjust under rope pressure to accept a variety of rope diameters. Teeth grip evenly with or without load.

Lightweight – overall weight only 7kg

Powerful – 2-speed gearing allows optimum use of manpower to deliver power and speed.

Reliable & Easy to Maintain – Composite roller bearings and bushings don’t require lubrication and have excellent corrosion resistance. This ‘metal-replacement’ material is completely non-reactive to saltwater and most chemicals, and has very good wear and abrasion resistance under maximum operating loads.

Load-carrying gears and pins are 17-4PH stainless steel for strength and durability.

Planetary gears are bronze to avoid stainless-on-stainless galling.

Winches can be disassembled and serviced where mounted.

Easy Line Control - Locking jaws hold loaded rope securely during operation and while suspended. The stripper arm is shaped to smoothly feed the rope in and out of the jaws so the operator can use both hands to turn the winch. The stripper arm adjusts to multiple positions after the winch is mounted so rope exit position can be optimized.

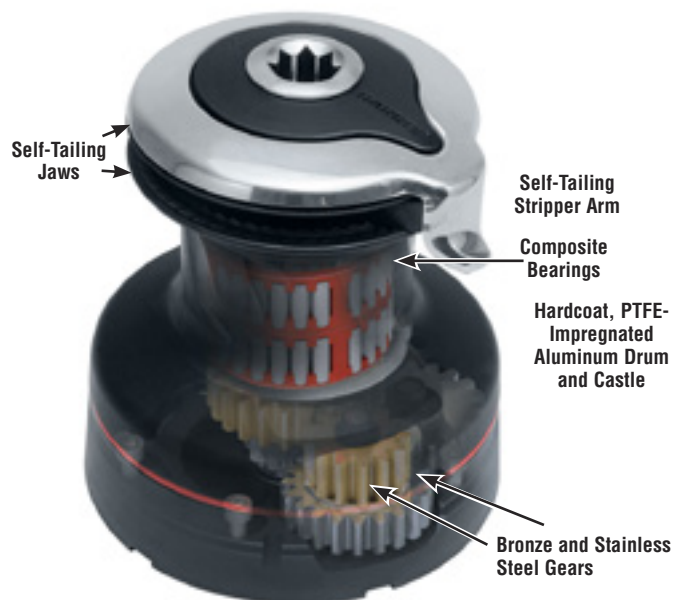

SPECIFICATIONS

Maximum Working Load:

Winch: 500 kg

Break Load: 2800 kg



WARNING! Subjecting the winch to loads above the maximum working load can cause the winch to fail or pull off the mounting plate suddenly, possibly resulting in severe injury or death.

| Part No. | Drum (D) | | Base (B) | | Height (H) | | Weight | | Rope entry height (LE) | | Rope Ø (Min - Max) | | Fastener circle | | Fasteners (HH) mm | Gear ratio | | | Power ratio | | |
|----------|----------|----|----------|-----|------------|-----|--------|-----|------------------------|----|--------------------|--------|-----------------|-----|-------------------|------------|------|---|-------------|-------|---|
| | in | mm | in | mm | in | mm | lb | kg | in | mm | in | mm | in | mm | | 1 | 2 | 3 | 1 | 2 | 3 |
| INRW500 | 3 1/8 | 80 | 6 3/16 | 157 | 6 7/8 | 175 | 8.4 | 3.8 | 3 1/4 | 82 | 5/16 - 1/2 | 8 - 12 | 4 7/8 | 123 | 5 x 6 | 2.13 | 6.28 | — | 13.50 | 39.90 | — |

A. PLAN INSTALLATION

The adapter plate can be affixed in a number of ways dependant on the environment and industry; from ratchet straps, M10 bolts, karabiners, to scaffold clamps, making for a truly universal and adaptable lifting solution.

It is the installer's responsibility to carry out all structural tests needed to ensure that the mounting surface can withstand the load.

Lifting Rope - Entry Angle

The winch plate must be installed so that the line can be led through the pigtail to the winch drum, with no more than 30° of line deflection in any plane. The installation should use pulley deflectors if necessary to ensure a fair lead to the winch. The pigtail should not take any angle load. (See diagram)

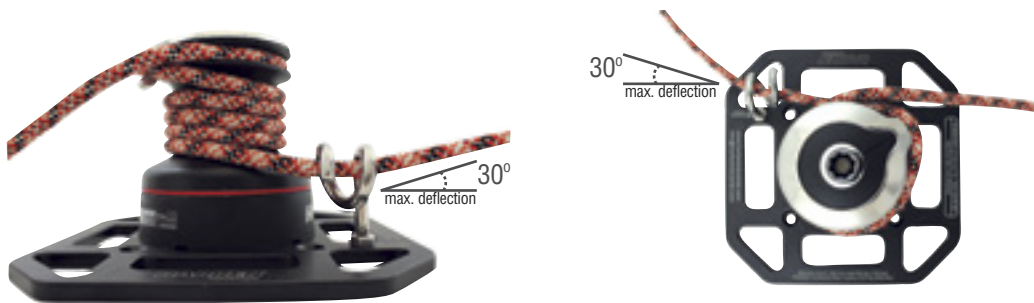

WARNING! Leading the rope directly on to the drum can cause overrides and damage winch or make winch inoperable, leading to loss of control, possibly resulting in severe injury or death. Always lead the rope through the pigtail.

Mounting Plate - Attachment

Ensure the plate is securely attached to the mounting surface, so that it can operate under load without significant movement.

The following illustrate some possible ways that the plate can be mounted.

Riggers Winch 500 - Location

The Winch kit must be installed in a position to allow sufficient working space around the unit, so not to impede operation of the handle.

The stripper arm must be in a 4 o'clock position once the plate is mounted.

The Winch kit must be installed in a position to ensure visibility of the lift trajectory by the operator at all times.

The following illustrate some possible ways that the plate can be mounted.



Installation



WARNING! Incorrect installation of winch may cause severe injury or death. Consult equipment supplier if in doubt about correct position of winch.

Pre-Use Checks

- 1) Check plate for damage (excessive wear, cracks, deformation)
- 2) Check underside of plate;
 - a) 5 fasteners around central hole, recessed 1 mm approx.
 - b) Pigtail end recessed 1 mm approx.
- 3) Winch base securely fastened to plate (small amount of play between winch drum and base is normal)
- 4) Pigtail is pointing towards drum (as per diagram)
- 5) Stripper arm is positioned correctly depending on orientation of plate
 - a) Wedge is correctly positioned behind stripper arm (see diagram)
- 6) Winch drum can be turned by hand clockwise
- 7) Winch drum cannot be turned by hand counter-clockwise
- 8) Handle can be inserted in winch and lock-in mechanism prevents accidental removal
- 9) Handle can be rotated in both directions, resulting in the winch drum rotating



PERSONAL PROTECTIVE EQUIPMENT

Wear gloves to protect against rope abrasion or chafe when operating winch.

LIFTING LOAD



IMPORTANT! Keep fingers, loose clothing, hair etc away from winch. Area around winch handle should be kept clear of people and objects at all times. Be sure to keep loose rope near winch to prevent tripping.

1. Feed the rope through the pigtail and, starting at the base of the winch, wind rope onto drum in a clockwise direction. Use at least four complete turns, but no more than six, depending on rope diameter. Excess turns may cause rope to override or may cause excessive friction. (*See images*).



Excessive turns at base of winch



Rope override



WARNING! Always put a minimum of 4 turns on winch drum. Fewer turns can severely decrease holding power which may result in rope slippage or failure to hold load, causing lifted load to fall, possibly resulting in severe injury or death.



WARNING! Never allow rope to override on winch drum. This can cause rope to jam and can prevent load from being lifted/lowered. Tension on loaded rope must be relieved to clear override. This procedure carries a risk of serious injury or death if load drops or becomes uncontrollable.

2. Pull rope through to take up any slack, then load into spring-loaded, self-tailing jaws by winding rope clockwise and pulling tight to engage. Self-tailing jaws act as locking mechanism so operator does not have to pull rope in or let it out while rotating the handle.



WARNING! Rope must be securely pulled into self-tailing jaws. Do not rely solely on rope turns to hold load. Stripper arm must be positioned correctly so that the weight of rope or any other force does not cause the rope to be pulled out of the jaws (*see images overleaf*). Check that rope remains secured in self-tailing jaws while cranking. Failure to secure rope in jaws may cause rope slippage which can cause lifted load to fall, possibly resulting in severe injury or death.

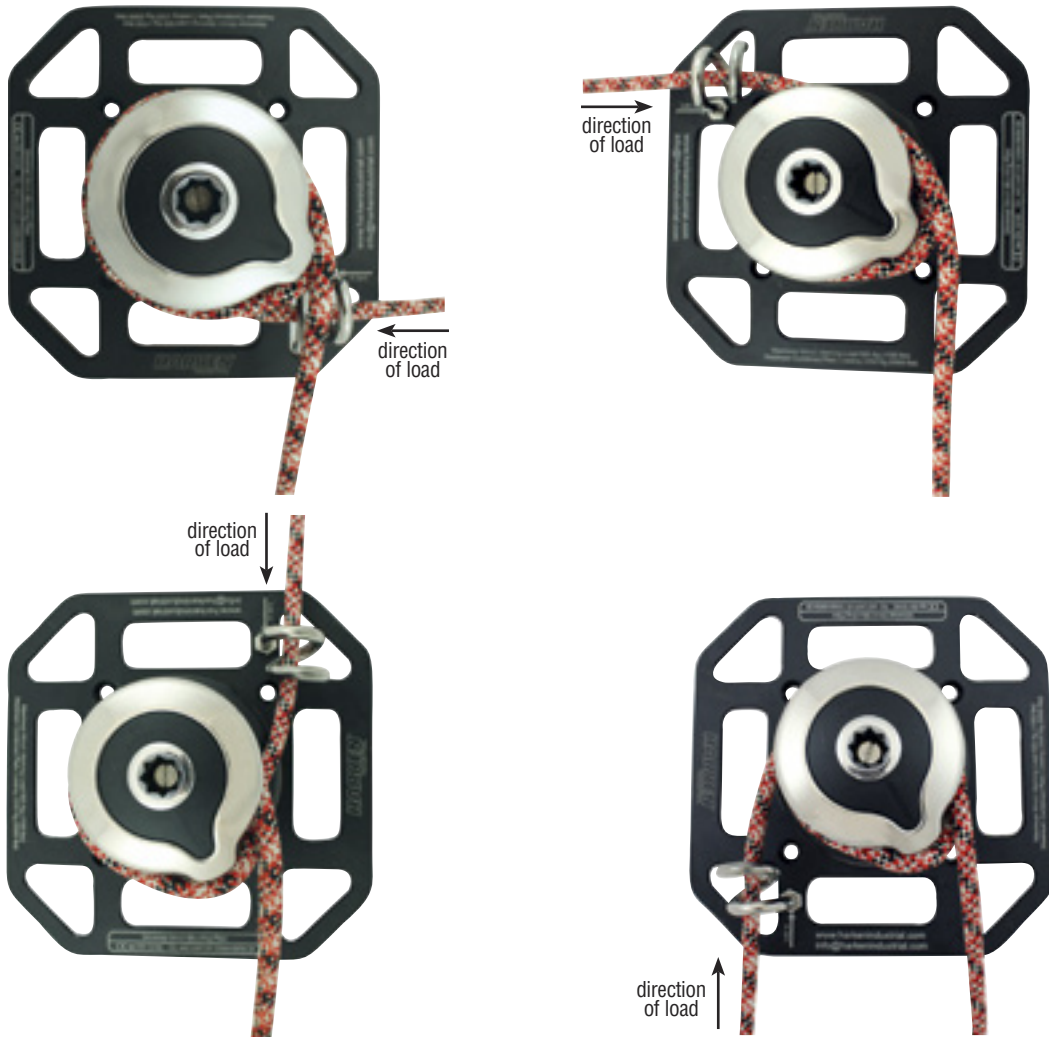

3. Begin turning handle counter-clockwise. Gears engage automatically depending on direction handle is rotated.

1st gear: rotate handle counter-clockwise

2nd gear: rotate handle clockwise

When handle becomes difficult to rotate in 1st gear, reverse direction to access 2nd. A higher power ratio makes a heavier load easier to lift with the same effort.



LOWERING LOAD

We recommend using a safety device, such as a grab-rope mechanism (eg. Prussic knot, rope-grab clutch).

1. Engage grab rope mechanism or clamp rope turns on drum with your hand.
2. Carefully unwind rope from self-tailing jaws only, while maintaining even tension on rope.
3. Do not take rope turns off winch drum until rope is completely unloaded.



WARNING! Use caution when lowering load using winch. Carefully hold rope when it is out of self-tailing jaws. Rope tail must not be released. Releasing rope tail will result in rope slippage, causing the load to fall, possibly resulting in severe injury or death.

Inspection

INSPECT BEFORE EACH USE

A formal inspection of the winch and its connection to the structure must be performed at least annually by a knowledgeable person other than the user. The inspection should be recorded in an inspection and maintenance log.

BEFORE EACH USE

Inspect winch and self-tailing jaws for degradation, cracks, or wear that may affect locking strength and operation. Check lifting rope to make sure that it is free from wear. If in doubt, replace with a suitably strong rope.

HEAVY USE/HARSH ENVIRONMENT

In addition to inspection before each use, a detailed monthly inspection of the unit is recommended. If unit is under heavy use and/or in a harsh environment inspect and lubricate frequently.

Maintenance

WASH

Wash winch frequently with fresh water.

Do not allow cleaning products or other caustic solutions to come into contact with winch, especially anodized, chrome-plated, or plastic parts. Do not use solvents, polishes, or abrasive pastes on logos or winch stickers.

MAINTENANCE SCHEDULE

Winch must be completely overhauled, cleaned, and lubricated at least every 12 months. Harsh environment and/or heavy use may require more frequent maintenance.

After inspection, replace worn or damaged components with genuine Harken parts. Do not replace or modify a Harken® Riggers Winch 500 with a part that was not designed for it.



CAUTION! Periodic service must be carried out regularly. Lack of adequate maintenance shortens the life of the Harken® Riggers Winch 500, can cause serious injury and also invalidate the warranty. Installation and maintenance of Harken® Riggers Winch 500 must be carried out exclusively by trained personnel.

Disassembly

DISASSEMBLY

To inspect the winch you must remove the drum.

| Tools You Will Need | |
|---|-------------------------------|
|  | Medium flat-blade screwdriver |
|  | Small flat-blade screwdriver |
|  | #5 Allen wrench |
| Protective gloves | |



1. Unscrew the central screw (2 Nm/18 in-lb)



2. Slide off the hub n°28 and the cover n°29



3. Unscrew the three screws n°27 (4 Nm/35 in-lb)



4. Remove the self-tailing arm n°26 by rotating and lifting it.



5. Lift off the drum n°22



6. Completely unscrew three screws n°27



7. Remove the self-tailing arm support n°21



8. Slide out the central shaft n°19



9. Unscrew the 6 stainless hex screws n°16 (8 Nm/71 in-lb) **NOTE** not those painted red

Disassembly



11. Remove the drum support n°15
Important: washer n°12 may remain inside the drum support!



12. Remove the washer n°12



13. Remove the gear n°7 and remove the pawls n°5. To facilitate the operation press the spring against the pawl with a blade.



14. Slide off gear n°3



15. Slide off gear n°14



16. Slide off gear n°10



17. Remove the pawls n°5. To facilitate the operation press the spring against the pawl with a blade.



18. Remove washer n°9

REPLACING SELF-TAILING JAWS

| Tools You Will Need | |
|---|--------------------------------------|
|  | Medium flat-blade screwdriver |

If it is necessary to replace winch jaws, proceed as follows:



Torque to apply when assembling



1. Unscrew four (4) screws (23)
( 4 Nm/35 in-lb)

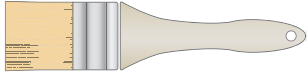

2. Remove jaws (22).

| Tools You Will Need | |
|--|-------|
|  | Brush |

- A** Anti-seize
- G** Harken® Grease
- O** Harken® Pawl Oil
- L** Loctite® 270

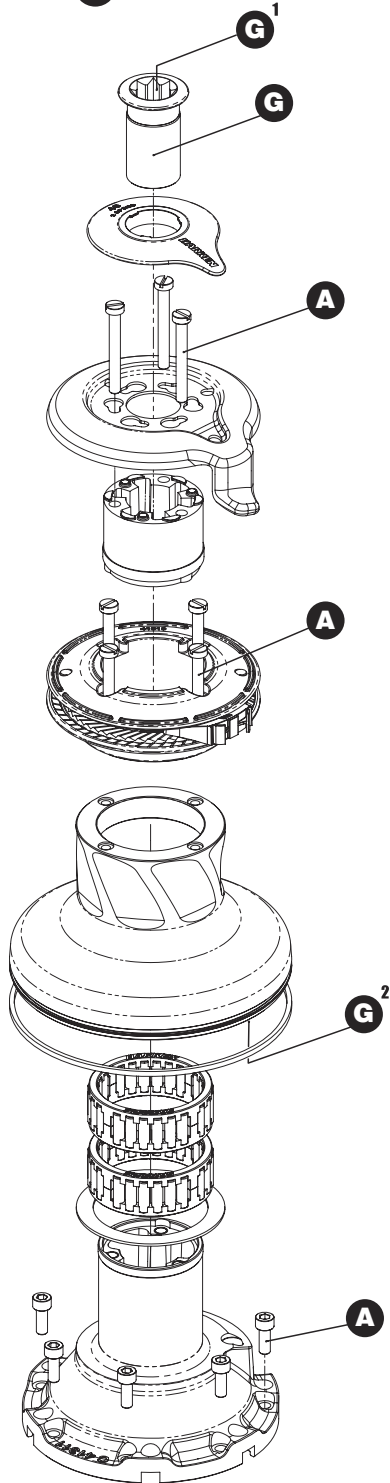

CLEAN

1. Use degreaser to soak metal components. Rinse plastic parts in fresh water.
2. Dry parts with rags that do not leave residue.
3. Inspect gears, bearings, pins, and pawls for any signs of wear or corrosion.
4. Carefully check teeth of gears and ring gears to make sure there are no traces of wear.
5. Check roller bearings to ensure there are no breaks in bearing cages.
6. Replace worn or damaged components. See Page 14 and Parts on Pages 16 - 17.

LUBRICATE

1. Carry out maintenance on components using products listed and shown below on exploded view.
2. Use brush to lightly lubricate all gears, gear pins, teeth, and all moving parts with Harken Grease.
3. Lightly lubricate pawls and springs with Harken Pawl Oil. **Do not use grease on pawls!**

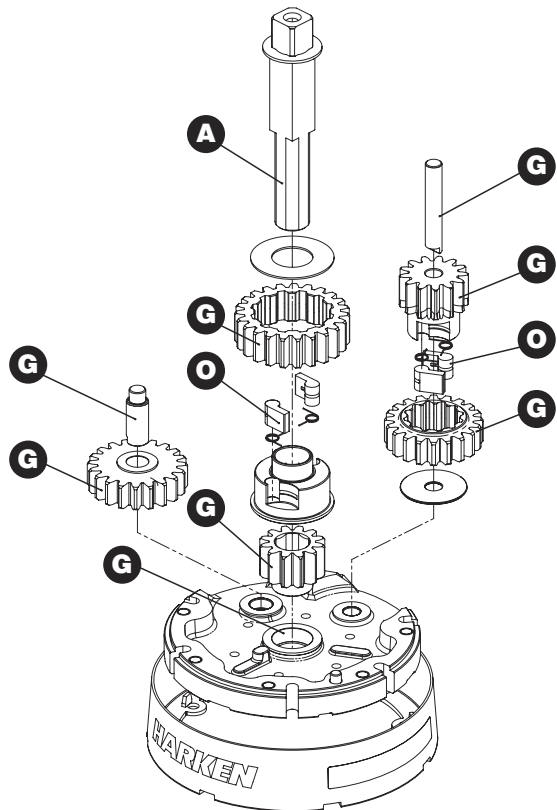

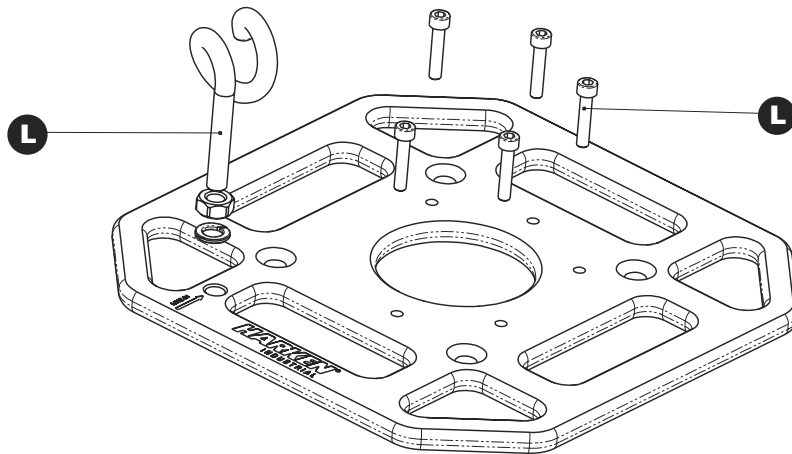

SPARE PARTS

Spare parts can be ordered from Harken as described in the Harken Worldwide Limited Warranty using the part number in the Parts List and the serial number of the winch, which is printed on a label on the drum support and on the skirt.

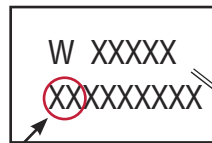

Last two numbers of the year of production, i.e. 10 for 2010.



Assembly

Make sure that the holes and drainage channels in the base of the winch are not obstructed. Assemble winch in reverse order of sequence in the Disassembly section.

To tighten bolts, use torque indicated in disassembly procedure.



When positioning stripper arm, align peeler with it.



If jaws have been disassembled, insert peeler between two jaws, taking care that letters "TOP" on peeler are facing upwards.

ASSEMBLE PAWLS

Correctly position spring in housing as shown at left. Hold spring closed and slide pawl into housing. Once in position, check that pawls can be easily opened and closed with a finger.

If you have questions concerning the assembly procedure contact Harken® Tech Service: techservice@harken.it.

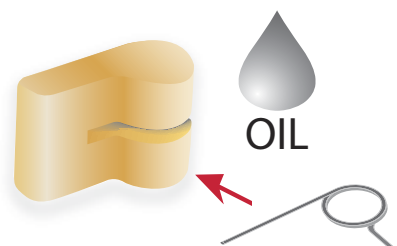

ASSEMBLY PLATE PROCEDURE

Tools You Will Need

| | |
|---|-------------------------------|
|  | Medium flat-blade screwdriver |
| Protective gloves | |



1. Install nut on pigtail.
NOTE. Pigtail should be installed with no thread locker.

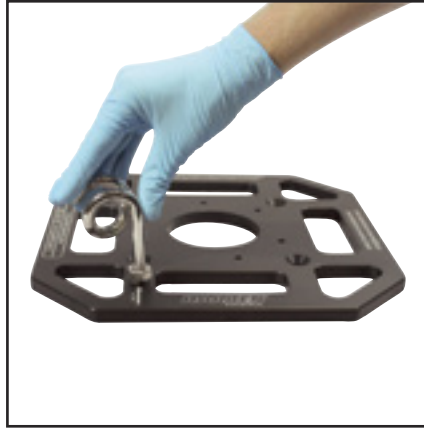

2. Wind pigtail into mounting hole (adjacent to "line in" arrow) as far as possible without it protruding through the plate.



3. Wind nut back down onto plate to lock pigtail in place with the end of the pigtail spiralling towards the winch line entry point



4. Remove winch handle socket.



5. Slide off the hub n°28 and the cover n°29



6. Unscrew the three screws n°27 (4 Nm/35 in-lb)



7. Remove the self-tailing arm n°26 by rotating and lifting it.



8. Lift off the drum n°22



9. Note down serial number of winch and record



10. Mount winch to plate using 5 x M5 bolts (painted red). Blue Loctite (243) should be used.



NOTE. To obtain correct Maximum Working Load (MWL), all five bolts, must be securely tightened (8 Nm/71 in-lb) into plate.



WARNING! Failure to use correct number of mounting fasteners and/or failure to tighten them correctly can result in winch pulling off suddenly and unexpectedly during high loads, which may cause load to drop, possibly resulting in severe injury or death.



11. Reassemble drum, stripper arm and socket. When the pigtail side of the plate is toward you, the stripper arm should point to 11 o'clock (330 degrees approx).

Harken accepts no responsibility for defective installation or reassembly of its winches. If you have questions or concerns, Harken Tech service is at your disposal at info@harkenindustrial.com



WARNING! Winch can only be aligned one way. Ensure stripper arm is aligned correctly according to the diagram. Incorrect alignment of the stripper arm can cause the rope to fall out of the jaws, leading to release of load, possibly resulting in severe injury or death.



WARNING! Ensure pigtail is aligned correctly according to the diagram. Misalignment of the pigtail can cause rope overrides, and loading stress, leading to loss of control, possibly resulting in severe injury or death.

Handling

Protect against extreme temperatures: -10° C to +40° C

Extreme heat may distort composite parts.

Extreme cold can cause the material to become brittle and cause the lubrication to congeal.

Storage

Store in clean/dry place

Avoid impact damage which could damage jaws and skirt; ensure good packaging when shipping.

Declaration of Conformity

Manufacturer — Harken Italy S. p. A.
 Via Marco Biagi, 14, 22070 Limido Comasco (CO) Italy
 Telephone: 031.3520031
 Web: www.harken.it, Email: info@harken.it

EC Declaration of Conformity



Harken UK Ltd, EU Representative declares that the product described hereafter:
RIGGERS WINCH 500– INRW500
 complies with the essential requirements of the Machinery Directive 2006/42/EC and carries the appropriate CE marking.
 Compliance has been demonstrated with reference to the harmonized standard;
BS EN 13157:2009 Cranes — Safety - Hand powered lifting equipment
 A technical file is retained for this equipment by the authorized manufacturer.

| | |
|--|--|
| Done at: Harken UK LTD | On: 10th Nov 2014 |
| Signature  Catherine Ash-Vie | Name Harken UK Ltd Bearing House, Ampress Lane Lymington SO41 8LW England |

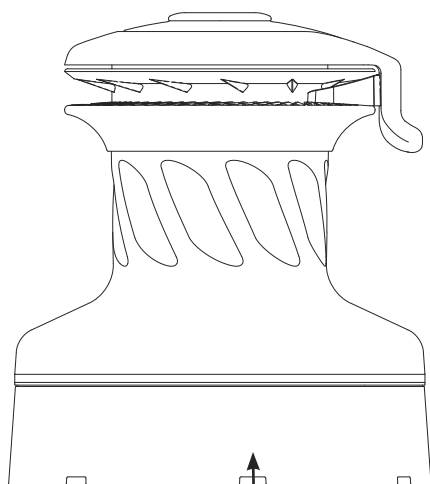
Explanation of Label



Label affixed to drum skirt

| | | | | |
|--|---|---|---|--|
| HARKEN Italy spa | | Riggers Winch 500 | | INRW500 |
| via Marco Biagi, 14 22070, Limido Comasco (CO) - Italy www.harken.com ☎ (+39) 031 3523511 | | CE EN13157:2009 |  minimum 4 turns clockwise | Serial No. / N. di serie W XXXXX XXXXXXXXX |
|  |  | rope diameter diametro fune ø 8-12 mm | Max Working Load (MWL) 500 kg | |

| | | | |
|---|--|---|---|
| 1 | | 2 | |
| 3 | | 5 | |
| 4 | | 6 | 7 |
| 8 | | | |

1. Manufacturer's name
2. Product name and code
3. Manufacturer's address
4. Pictogram instruction to read the manual
5. CE marked and tested to EN13157:2009 standard
6. Safety instruction to put a minimum of 4 rope wraps clockwise around drum; minimum rope diameter is 8 mm, maximum rope diameter is 12 mm
7. Serial number in format:

| | |
|---|-----------|
| W | XXXXX |
| X | XXXXXXXXX |

 last two numbers of the year of production (i.e. 10 = year 2010)
8. Warning! Maximum lifting load (maximum load for lifting persons)

EXPLODED VIEW 1/2

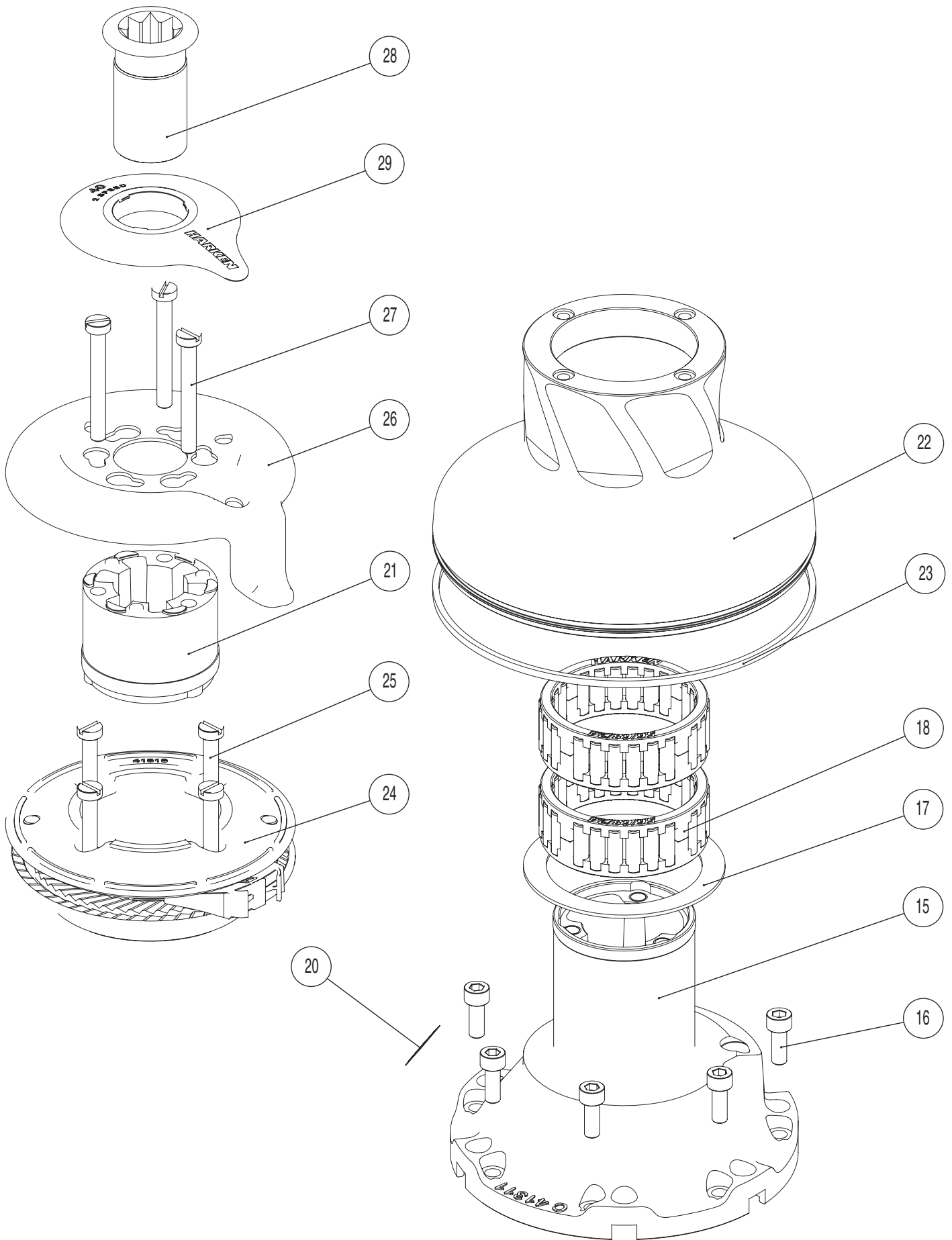

EXPLODED VIEW 2/2

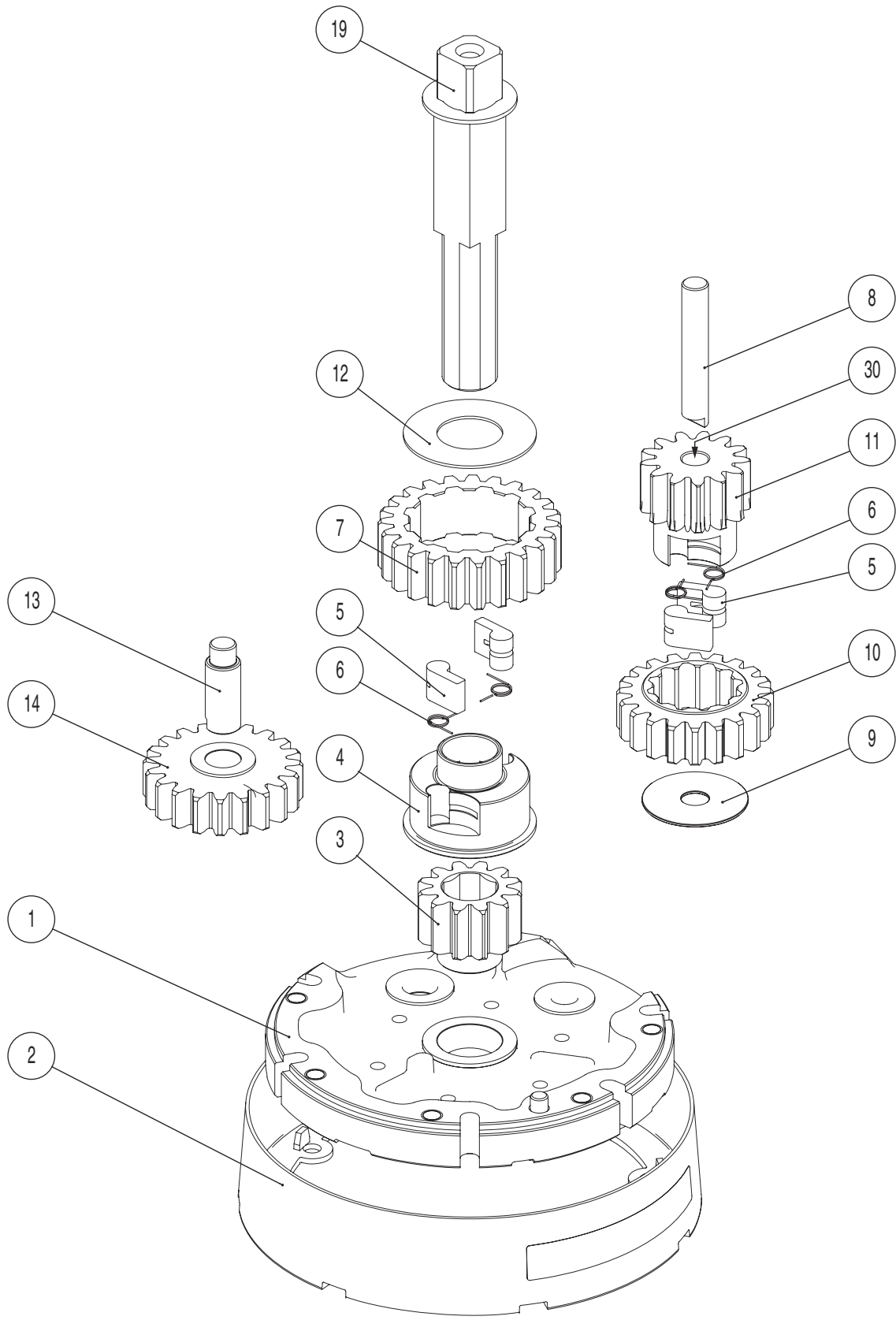

Riggers Winch 500

| Pos. | Q.ty | Code | Description |
|------|------|---------------|---|
| 1 | 1 | A94141300 | Winch 40 Base Assy <i>Winch Serial Number Sticker</i> |
| 2 | 1 | A94141400 | Assembly - Skirt Winch 40** |
| 3 | 1 | S 41302 00 04 | Gear Z12 |
| 4 | 1 | S 41303 00 04 | Pawls Carrier Ø8xN2* |
| 5 | 4 | S 00008 00 03 | Pawl Ø8* |
| 6 | 4 | S 00038 00 01 | Pawl Spring dia 8* |
| 7 | 1 | S 41283 00 41 | Gear Z23 |
| 8 | 1 | S 65738 00 04 | Pin |
| 9 | 1 | S279090002 | Washer 36x9,5x1* |
| 10 | 1 | S 41297 00 04 | Gear Z20 |
| 11 | 1 | S 65737 00 41 | Pinion Z13 |
| 12 | 1 | S 41312 00 02 | Washer Ø22.5xØ45x1* |
| 13 | 1 | S 41307 00 04 | Pin |
| 14 | 1 | A94130500 | Assy - Gear Z20 |
| 15 | 1 | A94141500 | Assy - Housing Winch 40 |
| 16 | 6 | M0635103 | Socket head screw M6x16 UNI 5931* |
| 17 | 1 | S41315 00 82 | Washer Ø62xØ80x1.5* |
| 18 | 2 | A74136000 | Bearing Ø56xØ68x24* |
| 19 | 1 | A94139000 | Assy - Central Shaft W36/40 |
| 20 | 1 | S418760063 | Winch Serial Number Sticker |
| 21 | 1 | S4129400A0 | Stripper arm support |
| 22 | 1 | S41417 00 53 | Drum A W40 |
| 23 | 1 | S281680097 | Red line |
| 24 | 1 | A94131800 | Assy - Winch 40 Jaws <i>Lower Jaw W35/40</i> <i>Upper Jaw w35/40</i> <i>Peeler W20-40</i> <i>Spring</i> |
| 25 | 4 | M0601803 | Screw UNI EN ISO 1207:1996 - M6x35 - A4* |
| 26 | 1 | S 41420 00 19 | Stripper Arm W35/40 |
| 27 | 3 | M6007103 | Screw M6x50 UNI6107* |
| 28 | 1 | A94136400 | Assy - Socket W20-80 <i>Screw M8x20 UNI 6109*</i> <i>Washer Ø7.7xØ25x5.8*</i> <i>Socket Handle W20/80</i> |
| 29 | 1 | S 41419 00 A5 | Cover 2 speed W40 |
| 30 | 1 | M603370094 | Bushing |

*Service kit available; see winch kit section on the website www.harken.com

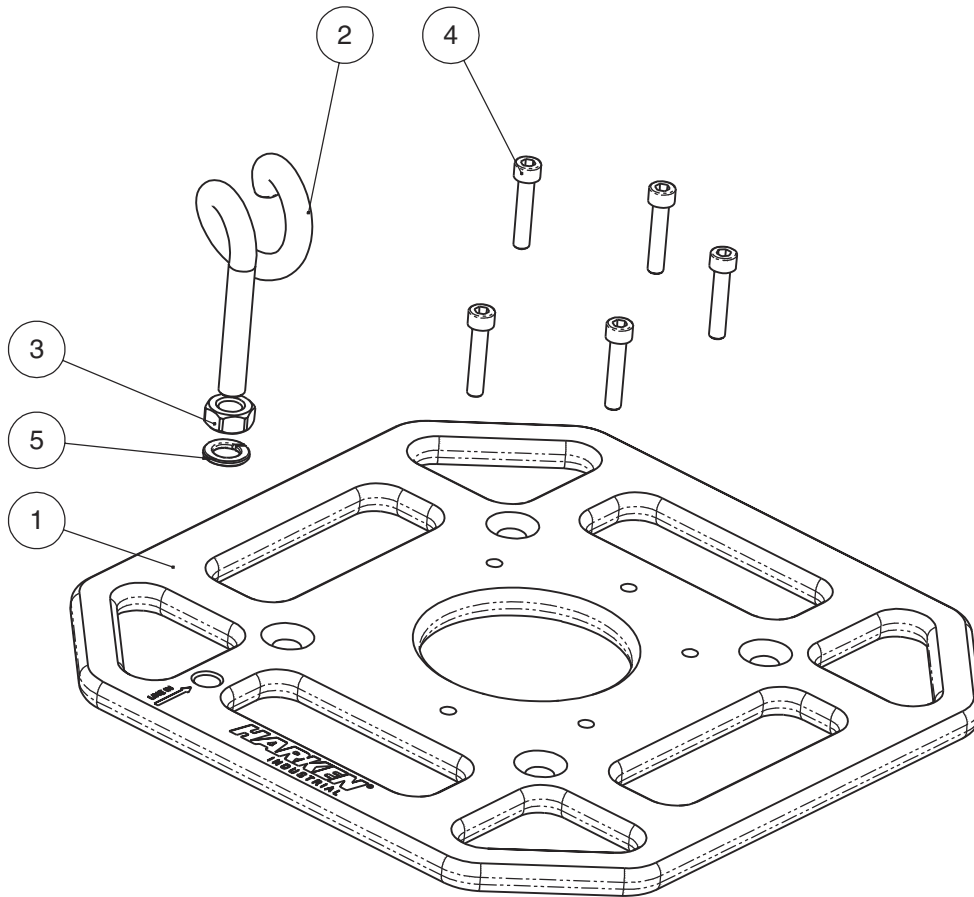

| Pos. | Q.ty | Code | Description |
|------|------|-------------|--------------------------|
| 1 | 1 | S 688540052 | Plate Riggers winch 500 |
| 2 | 1 | S 688560002 | DRIVE LINE |
| 3 | 1 | M 0602803 | Nut M10 UNI5588 |
| 4 | 5 | M 0624203 | Screw M6x30 |
| 5 | 1 | M 0611703 | Washer 10.5 U1751 DIN127 |

HARKEN®

Manufacturer

Harken Italy SpA.
Via Marco Biagi 14, 22070 Limido Comasco (CO), Italy
Tel 031.3523511; Fax 031.3520031
Web: www.harken.it
Email: info@harken.it

EU Representative

Harken UK Ltd
Bearing House, Ampress Lane
Lymington, Hampshire S041 8LW, England
Telephone: (44) 01590-689122 • Fax: (44) 01590-610274
Web: www.harken.co.uk
Email: enquiries@harken.co.uk

Worldwide Limited Warranty

Refer to the Harken Worldwide Limited Warranty on the website at <http://www.harkenindustrial.com/warranty.php>