

# PMI® DELTA HARNESS

SG51110, SG51111



PIGEON MOUNTAIN

**PMI**®  
INDUSTRIES

*Manufacturer's Instructions*





## PRODUCT DESCRIPTION

The Delta is a lightweight, comfortable harness that provides a clean, low profile for tactical operations, theatrical use, or any rigging and rescue applications at height. Gear loops for this harness can be added and are intentionally not pre-sewn for tactical and theatrical uses where gear loops may interfere with desired performance and function. It is black to remain unseen with tactical/theatrical clothing, has a Quick Clip Bent Bar D front attachment point, secure Double Back Buckles on the leg loops, a Quick Adjust Sliding Bar Buckle at the waist belt and it comes with a custom kit that can add multiple gear loops for carrying additional equipment.

## FEATURES

The Delta offers specific features for tactical operation, theatrical use, or any rigging and rescue applications at height as seen in **Diagram A**.

DIAGRAM A

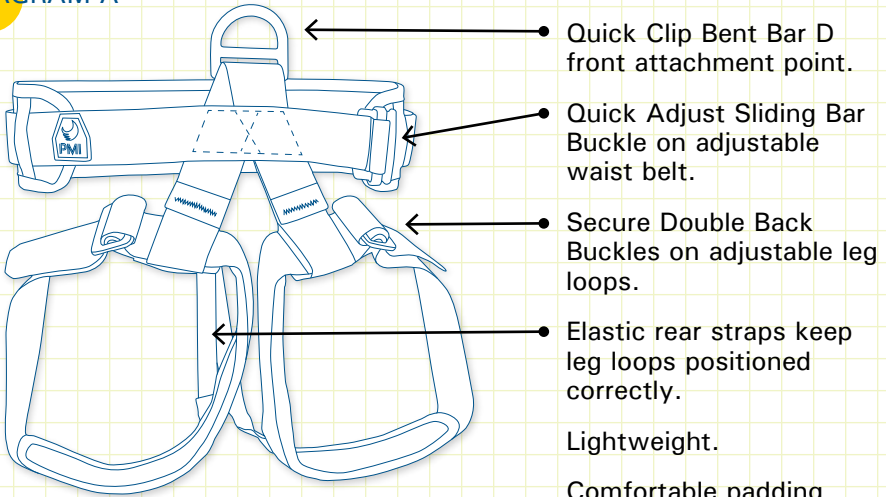

Lightweight.

Comfortable padding.

Black in color and low profile so as not to be easily seen.

Custom gear loop kit.

Sewn vertical webbing attachment points for custom gear loops.

DIAGRAM B

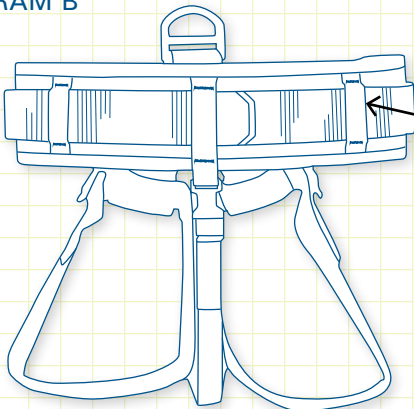

## SPECIFICATIONS

**MATERIALS:** Nylon webbing, nylon stitching, steel buckles.

**SIZE:** Standard, Waist: 31"- 45" Leg: 20"- 33"

**COLOR:** Black      **WEIGHT:** 1 lbs 7 oz (658 g)      **SKU#** SG51110

**SIZE:** Large-XL, Waist: 37"- 55" Leg: 23"- 37"

**COLOR:** Black      **WEIGHT:** 1 lbs 10.0 oz (748 g)      **SKU#** SG51111

## CERTIFICATIONS

MADE IN THE USA

## WARNINGS

### ⚠ **WARNING!**

#### ABOUT YOUR PERSONAL SAFETY

- You are responsible for your own safety and decisions while using this product.
- Before using this product you must thoroughly read and understand all Manufacturer's Instructions.
- Activities involving the use of this product are inherently dangerous; you must understand and accept the risks involved.
- Special training and knowledge are required for the use of this product.
- Failure to follow these stated warnings may result in serious injury or death.
- Keep these Manufacturer's Instructions, all product labels and the Equipment Inspection Log WITH the equipment so that any potential user can read them prior to use and make entries after use.
- Please contact PMI at 706-764-1437 to answer any additional questions regarding safety and use of this equipment.

### ⚠ **WARNING!**

This harness is intended for use in tactical operations, theatrical rigging, rescue applications and related activities at height. It should be used with compatible life safety equipment and by a person with sufficient knowledge of its proper use. The information in these instructions is not a substitute for the training and experience necessary to use the harness safely.

### ⚠ **WARNING!**

The Delta Harness is fitted with two different types of buckles for the waist belt and the leg loops. The waist belt has a Quick Adjust Sliding Bar Buckle to allow easy adjustment when properly rigged. The leg loops have Double Back Buckles that function differently than the Quick Adjust Sliding Bar Buckle. If not used properly, the buckles will not hold and can result in serious injury or death. Inspect the buckles on receipt of the harness and on the ground before using at height to ensure that they are functioning properly. [See Diagram C and D](#) for proper use and threading for both types of buckles.

## WARNINGS (continued)

DIAGRAM C

A Properly Threaded Quick Adjust Sliding Bar Buckle on the waist belt.

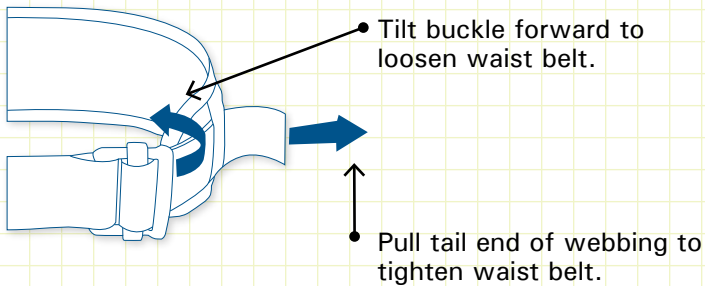
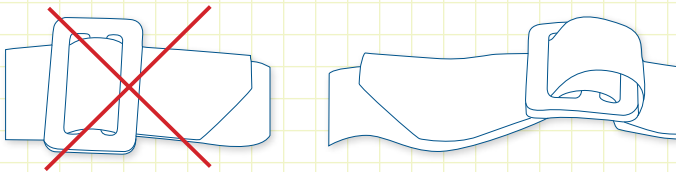

DIAGRAM D

A properly fastened Double Back Buckle.



### ⚠ WARNING!

Harness should not be used near moving machinery, electrical hazards, sharp edges, or abrasive surfaces without proper additional safety measures in place. All webbing tails should be properly secured before use.

### ⚠ WARNING!

Any accessory gear loop that is added to the harness is designed to attach equipment only and should NEVER be used for life safety applications such as belaying, anchoring a person, or tying into a life safety system.

### ⚠ WARNING!

The user should have a rescue plan prepared and the means available to implement it while wearing this harness.

## FITTING & USE

This harness is designed to have a low profile and remain unseen in desired situations. Often in tactical operations and theatrical rigging, there is less need for gear loops. We give you the option to attach your own gear loop(s) if you choose by providing a custom gear loop kit with this harness. To secure gear loop(s) properly, see the section of these instructions titled, "Delta Gear Loop Attachment Instructions". The Delta Harness is also designed to have a waist belt buckle that adjusts easily and quickly. The design of the leg loop buckles allows them to stay secured by using buckles that are fastened correctly when doubled back. Make sure you understand the section, "How to put the harness on correctly" in order to know the differences in the buckles and how they function.

### HOW TO PUT THE HARNESS ON CORRECTLY

- To ensure a proper fit of the Delta Harness, please follow the fitting steps in consecutive order in the section below.

DIAGRAM E

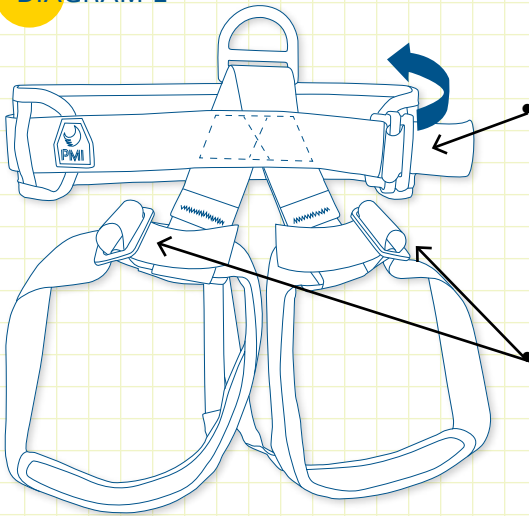

#### **Delta Quick Adjust Sliding Bar Buckle:**

Loosen the waist belt by tilting the Quick Adjust Sliding Bar Buckle and sliding the slack tail end of the webbing towards the buckle. Do not unthread the webbing from the buckle.

#### **Delta Double Back Buckle:**

Loosen leg loops by sliding the slack tail end of the webbing towards the buckle so that you create a bight of webbing that is positioned in the middle of the buckle. Pull the slack bight of webbing out of the buckle opposite of the tail end of the webbing to adjust the harness to its largest size. Do not pull the webbing completely through the buckle.

## FITTING & USE (continued)

DIAGRAM F

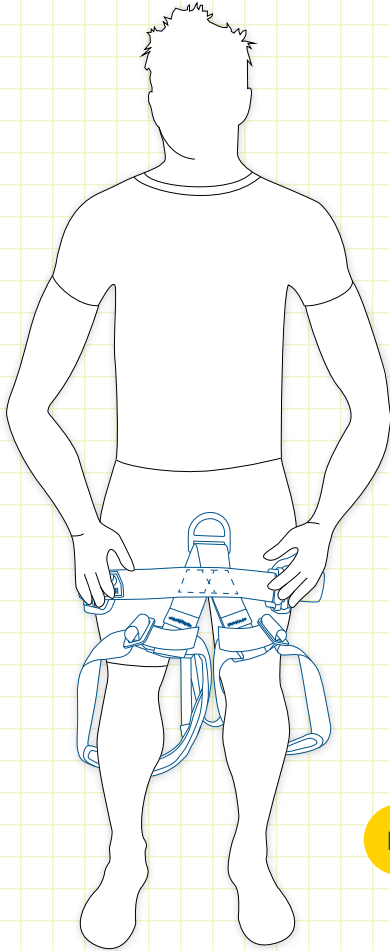

- Step through the top of the waist belt, inserting a leg into each leg loop with the buckles facing out in front of your body. The elastic rear strap should be oriented at the top of the leg loops and there should be no twists in the straps. The harness webbing should not be twisted and both buckles should look the same on each leg.

DIAGRAM G

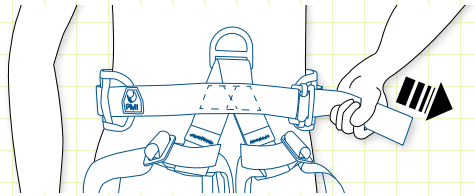

- Position the harness so that the waist belt wraps over the top of the hip bones and so that the Quick Clip Bent Bar D front attachment point is at about belly button level. Secure by slightly tilting the buckle and by pulling back on the tail end of the waist belt webbing, as shown in **Diagram G**.

## FITTING & USE (continued)

DIAGRAM H

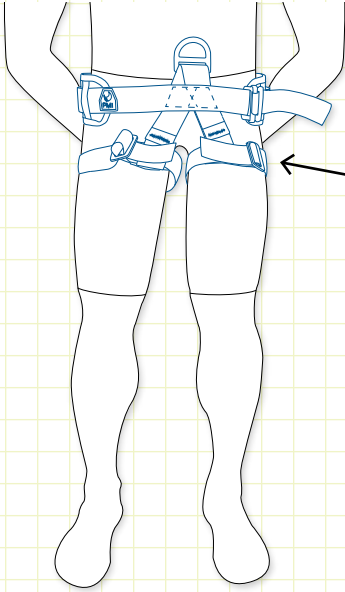

- Secure the leg loops comfortably around the thigh by pushing the leg loop webbing to create a bight of webbing in the center of the buckle. Pull the side of the bight of webbing farthest from the tail end of the webbing out so that the slack is taken out of the leg loop and is snug around the thigh.
- Pinch the buckle and webbing to hold in place, then with the other hand pull the tail end of the webbing until the bight and all slack gets taken out of the webbing and the leg loop stays firmly in place.

DIAGRAM I

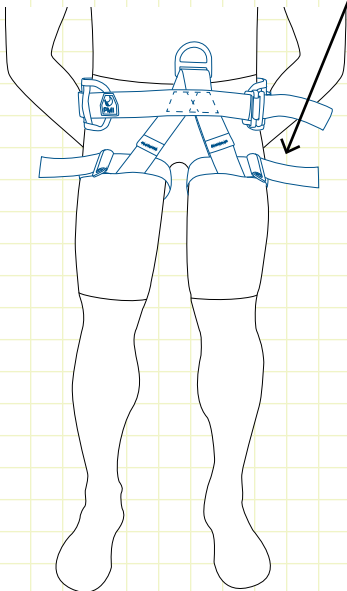

- When each buckle is tightened to the desired snug fit, take the tail end of the webbing, tilt the buckle slightly and slide the webbing through the far side of the slot in the buckle and pull tight to double back the buckle. Once the webbing is doubled back through the buckle, there should be no less than 3 inches of the tail end of webbing left. If there is less, then readjust until you get 3 inches of webbing or choose a larger size Delta Harness. A Double Back Buckle that is fastened correctly so that it is secure and will not slip is pictured in **Diagram D**.
- Ensure that the leg loops and waist belt are comfortable but snug enough so that the harness stays firmly in the proper position. You **SHOULD NOT** be able to slide the harness down over the hips once fastened correctly.
- Finally, adjust the rear straps so that the slack is taken out.



## INSPECTION, CARE & MAINTENANCE

Your harness should be thoroughly inspected before each use. Any harness that does not pass inspection should be retired from service, destroyed and discarded.

### **Inspections should include:**

- Examination of all load-bearing components for signs of damage.
- Inspection of all stitching for signs of wear, fraying, breaks, loosened/pulled threads, or cuts.
- Inspection of webbing for signs of cuts, burns, discoloration, broken fibers, hard/soft sections, or excessive wear.
- Examination of buckles and attachment points for proper function.
- Examination of all metal components for corrosion, damage or sharp edges.
- Inspection of webbing rigging and buckles to ensure that harness has been properly assembled.
- Inspection for any signs of damage from heat, chemical exposure, or other environments.
- Inspection of date of manufacture and date placed in service to determine if retirement of harness is needed (See "Retirement Criteria" section).
- Inspections should be recorded and maintained in an Equipment Inspection Log. A sample is provided in these instructions.

### **CARE AND MAINTENANCE**

Maintaining your harness properly will provide a longer service life and ensure the highest level of safety during use.

#### **The following maintenance guidelines should be followed:**

- Store harness loosely packed in a clean, dry environment.
- Thoroughly air dry a wet harness before storing it; never dry in a heated dryer.
- Keep your harness away from exposure to direct flame or high temperatures such as in a hot car.
- Prevent exposure of your harness to chemicals or other damaging substances.
- No repairs or modifications to this harness should be performed by anyone other than the manufacturer, excluding the addition of the gear loop kit, or warranty shall be voided and safety features could be compromised.

#### **Cleaning your PMI® Delta Harness**

**Washing** - If your harness is dirty, you can wash it by hand or in a front-loading commercial washing machine. Use a PMI® Laundry bag for keeping the harness from getting tangled/damaged when washing in a machine. Wash harness by using cool to warm water <30°C (<86°F) with a mild soap. PMI recommends using PMI® Rope Soap; otherwise non-detergent soaps are best. Soap used should not contain any bleaching agents.

*Inspection, Care and Maintenance continued on next page...*

## INSPECTION, CARE & MAINTENANCE (continued)

### DO NOT:

- DO NOT use top loading washing machines with agitators because they tangle/damage the harness severely and can cause damage to the machine.
- DO NOT use a commercial dryer to dry the harness.
- DO NOT leave a wet harness on a surface where contaminants may leach (such as concrete).
- DO NOT expose the harness to exhaust fumes.

**Disinfecting** - Disinfection of a harness may occasionally become necessary, such as when exposed to bloodborne pathogens. To disinfect a harness from suspected bloodborne pathogens, PMI recommends following the NFPA standard for cleaning rescue gear of bloodborne pathogens. Keeping in mind that undiluted household bleach is known to damage nylon, NFPA calls for using a diluted solution of household bleach to clean rescue gear. Add 60 ml of household bleach per 4 liters of tap water. That's about one quarter (1/4) cup of bleach per gallon of water.

**Be aware that some commercial bleach solutions are stronger than the recommended 1.5% that is typical for household bleach.** Soak the gear in the diluted solution for ten minutes, then rinse thoroughly with tap water. The rinsing cycle is critical to prevent any damage to the nylon from the bleach. It is good to soak the gear in tap water for the same amount of time it soaked in the bleach solution. Never store gear while it is wet.

### ⚠ WARNING!

The use of bleach over a long period of time, in repeated uses, can cause damage to fibers such as nylon. Disinfection of the harness using bleach should be used sparingly and only when needed.

**Drying** - Dry your harness in a clean, dry area out of direct sunlight. For best results, it should be hung up to air dry in a low-humidity environment. DO NOT leave a wet harness on a surface where contaminants may leach (such as concrete).

**Write It Down** - Remember to record the cleaning on the Equipment Log.

**Keep It Clean** - Store your harness in a clean, dark, dry environment, away from exposure to acids, other harmful chemicals, noxious fumes or other abuse.

### RETIREMENT CRITERIA

- RETIRE IMMEDIATELY any harness where the stitching is cut, torn, excessively worn or visibly damaged.
- RETIRE IMMEDIATELY if harness has been in service for 5 years or more, it must be retired even if a visual inspection reveals no concerns.
- RETIRE IMMEDIATELY any harness whose strength may have been compromised during use.
- RETIRE IMMEDIATELY any harness which is subjected to a major fall or uncontrolled or excessive loading.
- RETIRE IMMEDIATELY any harness with a manufacture date which is greater than 10 years old, regardless of history and usage.
- RETIRE IMMEDIATELY any harness whose history and past usage you

## **INSPECTION, CARE & MAINTENANCE** (continued)

are uncertain about.

- **RETIRE IMMEDIATELY** any harness that has been exposed to heat, direct flame or excessive abrasion.
- **RETIRE IMMEDIATELY** any harness that has been exposed to liquids, solids, gases, mists, or vapors of any chemical or other substance that can deteriorate the harness materials.
- **RETIRE IMMEDIATELY** any harness that does not pass inspection.
- **RETIRE IMMEDIATELY** any harness that raises any doubt about its safety or serviceability.

### **⚠ WARNING!**

**CUT ANY RETIRED HARNESS** to discourage future use and discard it entirely. A retired harness should not be stored, kept or maintained in such a way that it could inadvertently be used again.

## DELTA GEAR LOOP ATTACHMENT INSTRUCTIONS

This harness is designed to have a low profile and remain unseen in desired situations. Often in tactical operations and theatrical rigging, there is less need for gear loops. We give you the option to attach your own gear loop(s) if you choose by providing a custom gear loop kit with this harness. To secure gear loop(s) properly, follow the directions in consecutive order in the section below. If you have any questions please contact PMI at [custserv@pmirope.com](mailto:custserv@pmirope.com) or by phone at 706-764-1437 or 1-800-282-ROPE (7673).

### ⚠ WARNING!

Any accessory loops added to the harness are designed to attach equipment only and should NEVER be used for life safety applications such as belaying, anchoring a person, or tying in to a life safety system.

- The Delta Harness is equipped with gear-loop attachment points on the waist belt. Locate these by identifying the vertical webbing bands that secure the belt to the pad. (see [Diagram 1](#))

DIAGRAM 1

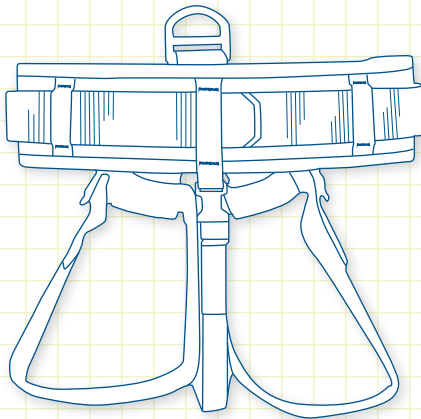

- Determine the length to cut each piece of tubing, based on your preferred gear loop size/configuration. Examples of different configurations are given on the waist belt in [Diagram 2](#). We recommend that each piece of tubing should be about 2 inches longer than the distance between the webbing attachment points on the harness. In [Diagram 2](#), the middle gear loop is for a Standard size Delta Harness, product #SG51110. In this example, the distance between the webbing attachment points is 5 inches so we cut 7 inches of tubing to create one gear loop that hangs down even with the bottom of the waist belt. You may adjust these lengths to accommodate your preferences.

DIAGRAM 2

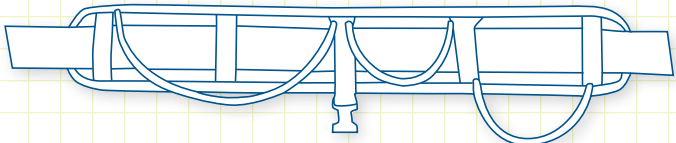

## DELTA GEAR LOOP ATTACHMENT INSTRUCTIONS (continued)

- Choose the webbing attachment points you will use and begin tying to the attachment point furthest to the right. First, tie a stopper knot (Overhand or Figure 8) in one end of the cord and thread the other end through one of the narrow slots nearest the top of the waist belt. You may have to use a blunt, stiff object to get the cord through, but make sure the object has a rounded end so as to not damage the harness fabric or stitching. Thread the cord back through the same slot in the same direction to form a loop around the  $\frac{3}{4}$ " webbing as seen in **Diagram 3**.

DIAGRAM 3

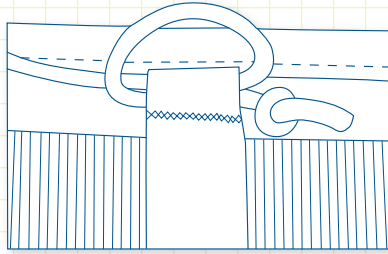

- Tie another stopper knot on the other side of the webbing as shown in **Diagram 4**.

DIAGRAM 4

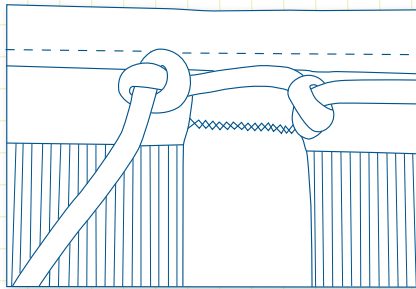

- Thread the cord into the section of tubing cut for the first gear loop. Then, tie a stopper knot next to the end of the tubing as shown in **Diagram 5**.

DIAGRAM 5

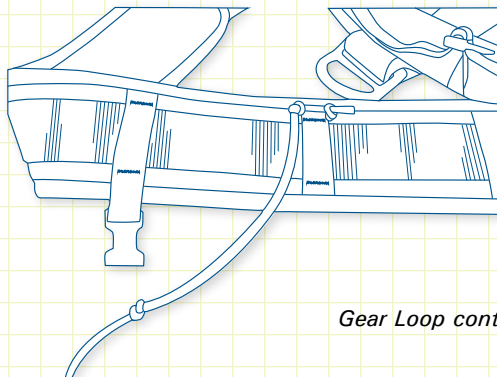

*Gear Loop continued on next page...*

## DELTA GEAR LOOP ATTACHMENT INSTRUCTIONS (continued)

- Take the loose end of the cord and thread it through the narrow slot at the top of the vertical webbing attachment point near the top of the waist belt.
- Make sure to form a loop around each attachment point, as shown in **Diagram 3**.
- Tie a stopper knot after looping the cord through the last gear loop attachment point as seen in **Diagram 6**. NOTE: For greater security at the terminating ends of the gear loop, consider using a Figure 8 Knot or other bulky knot of your choosing.

DIAGRAM 6

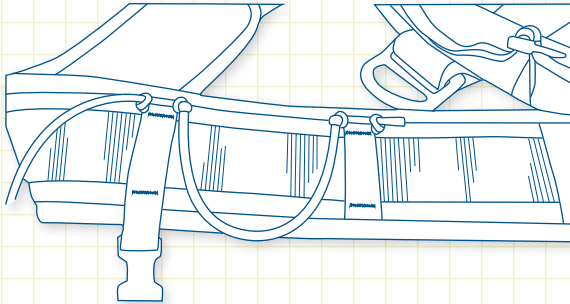

- Cut and heat seal the end of the cord to remove any loose ends. The end product should look similar to **Diagram 7**.
- Repeat steps 1-10 for each additional gear loop you may choose to add.

DIAGRAM 7

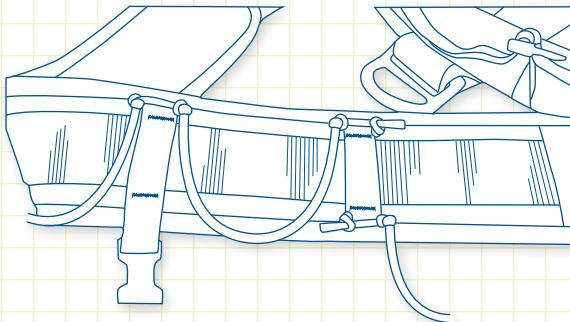















For more information about this or other PMI products, please contact us at:

PIGEON MOUNTAIN INDUSTRIES  
PO Box 803  
LaFayette, GA 30728, USA

706-764-1437  
1-800-282-ROPE (7673)

custserv@pmirope.com  
PMIROPE.COM

**⚠ WARNING**

- YOU COULD BE KILLED OR SERIOUSLY INJURED IF YOU DO NOT READ AND UNDERSTAND THIS BOOKLET BEFORE USING PRODUCT.
- SPECIAL TRAINING AND KNOWLEDGE ARE REQUIRED TO USE THIS PRODUCT.
- YOU MUST THOROUGHLY READ AND UNDERSTAND ALL MANUFACTURERS INSTRUCTIONS BEFORE USE.
- USE AND INSPECT THIS PRODUCT ONLY IN ACCORDANCE WITH THE MANUFACTURERS INSTRUCTIONS.
- YOU CAN CONTACT THE MANUFACTURER AT 706-764-1437 FOR IMPORTANT SAFETY INFORMATION.

**PMI LIMITED WARRANTY**

PMI products are warranted to the original retail purchaser to be free from defect in material and workmanship for a period of one year. PMI will repair or replace the item without charge provided inspection at our factory discloses no misuse or alteration, which, in our judgment, has affected the condition or functioning of the product. All implied warranties imposed by law in connection with the sale of PMI products are also limited in duration to a period of one year. PMI expressly excludes and shall not be liable for any consequential damages arising out of any breach of the express or implied warranties on sales of PMI products. Because of the high risks involved in high angle rope work such as, but not limited to, rescue, rope access, caving, rappelling, rock climbing and mountaineering, no further warranties exist or are implied by PMI. Regulations issued under the Magnuson-Moss Warranty Act require us to include the following statement: some states do not allow limitations on how long an implied warranty lasts nor the excluding or limitation of incidental or consequential damages, so the above limitations may not apply to you.

Thank you for purchasing PMI products!